

## C7 AND C9 Bulk Reels and Stringers

Lamp Installation instructions for XC7, XC7-M, XC9 and XC9-M series

**CAUTION:** To avoid electric shock, disconnect power prior to installing lamps or servicing in any way! Light string product must be installed according to these instructions to prevent electrical short and fire hazard.

**WARNING:** Before installing lamps into light string sockets, inspect the inside of the socket to ensure that the metal tab is positioned horizontally along the bottom. If the metal tab is standing up vertically, push it down to a horizontal position before screwing in the lamp. If the metal tab is not positioned correctly, this tab could make contact with the side of the lamp, causing an electrical short. See Figure 1.

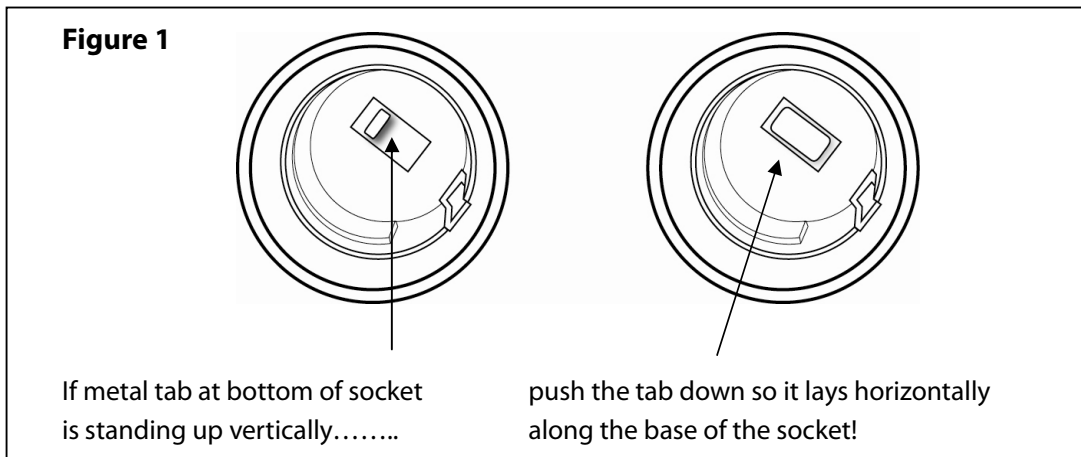

**CAUTION:** DO NOT EXCEED THE MAXIMUM LOAD IN ANY SINGLE RUN!

- For C7 and C9 bulk reels and 100 foot stringers, the maximum allowable load is 1000 watts (18AWG SPT-2 wire).
- For 25 foot and 50 foot stringers, the maximum allowable load is 600 watts (20AWG SPT-1 wire).

To figure out the amperage for any run using incandescent lamps, use this formula:

$$\frac{\text{Total Number bulbs} \times \text{Bulb wattage} \times 1.05}{120} = \text{Total Amps}$$

To figure out the amperage for any run using LED bulbs, please contact factory.